

BRZI DVOSTEPENI OSCILATOR SA NOVOM ELASTIČNOM STRUKTUROM



A FAST TWO-STAGE OSCILLATOR WITH A NEW ELASTIC STRUCTURE

Veljko Milković

akademik SAIN & EAN / academician of SAIN & EAN



Brzi dvostepeni oscilator sa novom elastičnom strukturom

A Fast Two-Stage Oscillator with a New Elastic Structure



BRZI DVOSTEPENI OSCILATOR SA NOVOM ELASTIČNOM STRUKTUROM



A FAST TWO-STAGE OSCILLATOR WITH A NEW ELASTIC STRUCTURE

Veljko Milković

akademik SAIN & EAN / academician of SAIN & EAN



Istraživačko-razvojni centar Veljko Milković – VEMIRC
Veljko Milkovic Research & Development Center – VEMIRC
Novi Sad, Srbija / Novi Sad, Serbia

BRZI DVOSTEPENI OSCILATOR SA NOVOM ELASTIČNOM STRUKTUROM

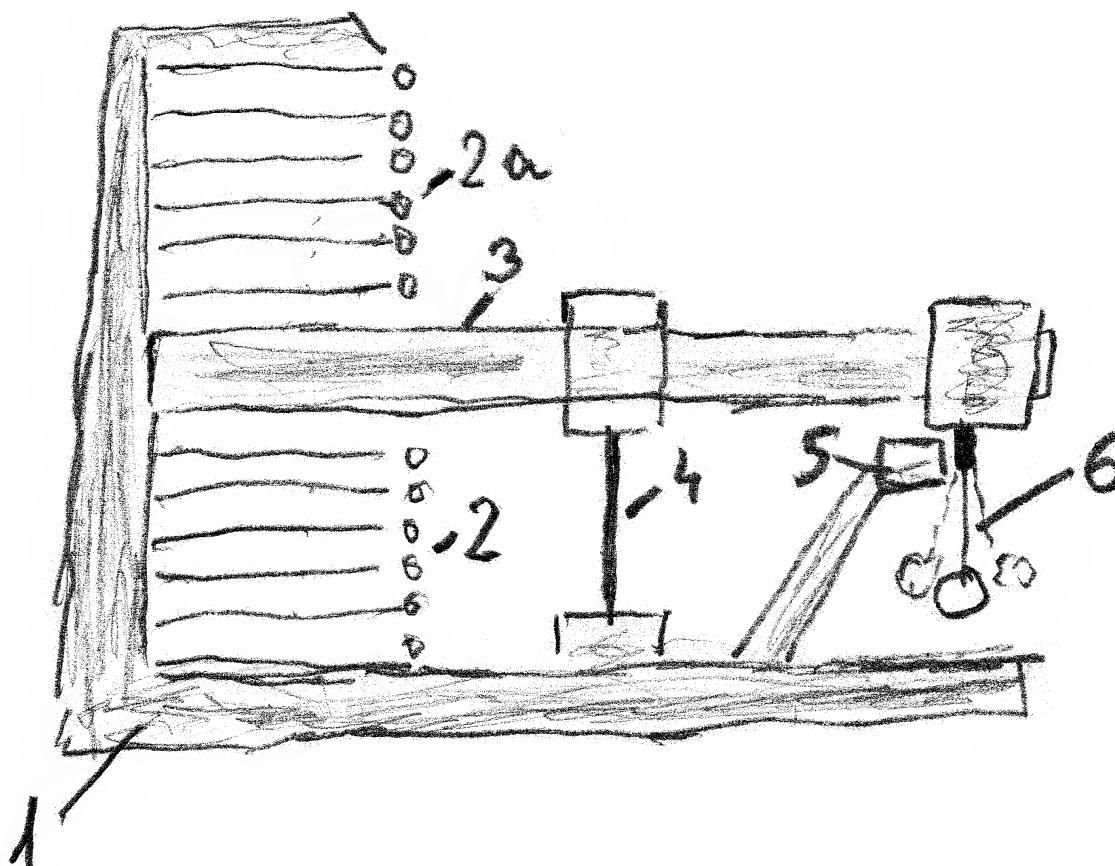

Slika 1.

- 1 – postolje
- 2 – donji piezoelektrični stub
- 2a – gornji piezoelektrični stub
- 3 – poluga
- 4 – elastični nosač poluge
- 5 – elektromagnetni automat (slično električnom zvonu, gde se može koristiti i tajmer (vremenski okidač) kako bi se samo povremeno uključivao)
- 6 – brzo elastično klatno sa malom amplitudom (po potrebi vertikalno, koso ili horizontalno)

Kod dosadašnjih modela dvostepeni oscilatora zastupljene su veće amplitude fizičkog klatna, koje su bile podesne posebno za pumpe za vodu (patent P-577/99). Nakon toga, zvanično je objavljeno još 30-ak tehničkih rešenja.

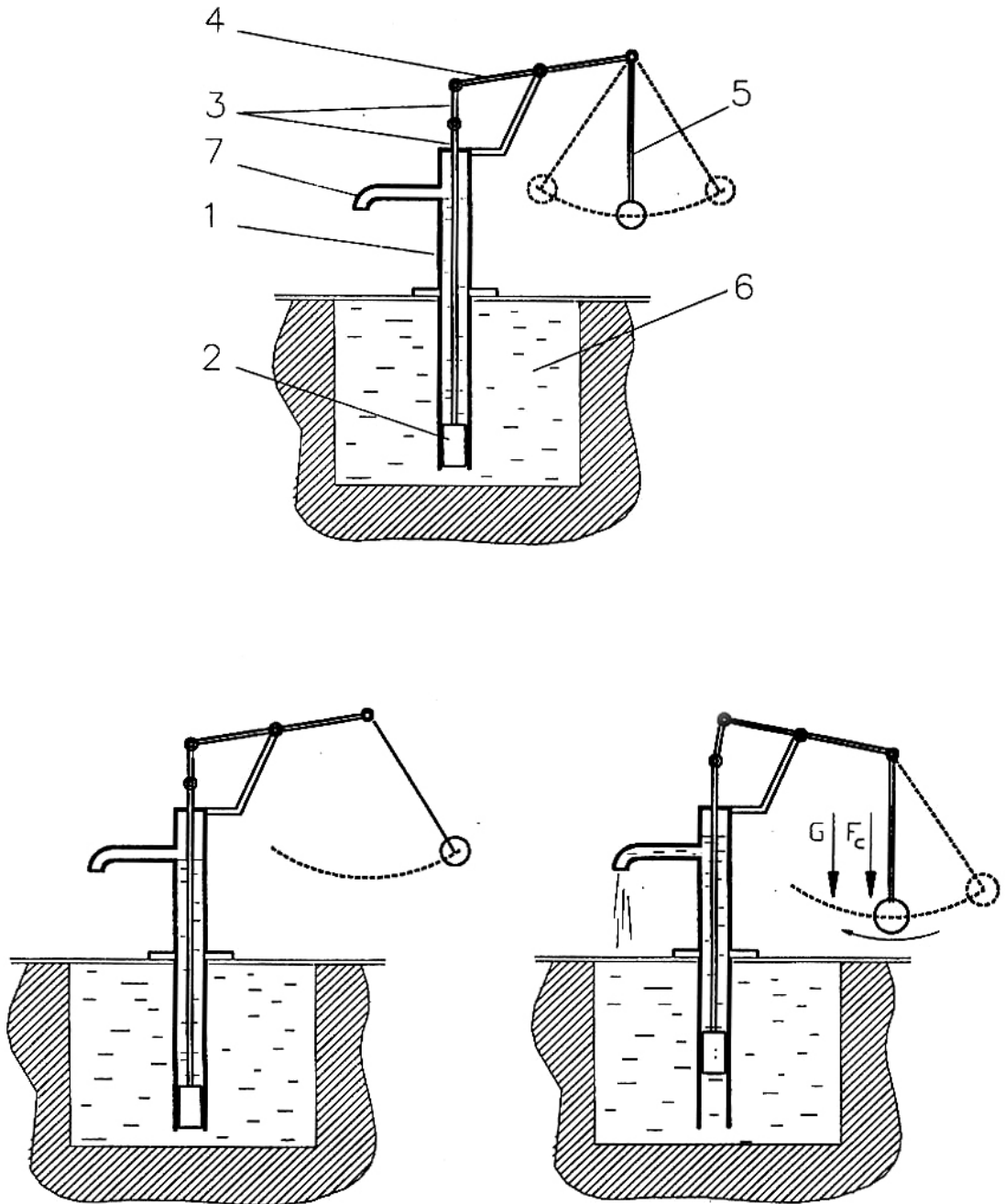

Slika 2. Crteži iz patente prijave broj P - 577/99 – Ručna pumpa za vodu sa klatnom (pronalazač: Veljko Milković; datum prijave: 10. novembar 1999) objavljeni u Glasniku intelektualne svojine Zavoda za intelektualnu svojinu Republike Srbije tokom procesa formalnog ispitivanja.

(19) SRBIJA I CRNA GORA

(12) Patentni spis (11) **49002 B**



(51) Int. Cl.⁷

F 04 B 9/14

ZAVOD ZA
INTELEKTUALNU SVOJINU
BEOGRAD

(21) Broj prijave: **P-577/99**
 (22) Datum podnošenja prijave: **10.11.1999.**
 (43) Datum objavljivanja prijave: **28.05.2001.**
 (45) Datum objavljivanja patenta: **30.04.2003.**
 (30) Međunarodno pravo prvenstva:
 (61) Dopunski patent uz osnovni patent broj:
 (62) Izdvojen patent iz prvobitne prijave broj:

(73) Nosilac patenta:
MILKOVIĆ VELJKO,
Bul. Cara Lazara 56,
21000 Novi Sad

(72) Pronalazač:
MILKOVIĆ VELJKO

(74) Zastupnik:

(54) Naziv: **RUČNA PUMPA ZA VODU SA KLATNOM**

(51) Int. Cl.⁷

F 04 B 9/14

(57) Apstrakt:

Pronalazak, ručna pumpa za vodu sa klatnom, sastavljen je iz tela pumpe (2) u obliku cilindra u kojem je smešten klip (1) sa klapnom (10) koja je jednosmerno propusna za vodu, tj. voda može da prolazi kroz klip (1) samo prema gore i to kada se on kreće prema dole. Za klip (1) je čvrsto spojena poluga (9) koja je sa gornje strane zglobno spojena sa polugom (8). Poluga (8) je sa druge strane zglobno spojena sa jednim krajem dvokrake poluge (6), koja je okačena na osovinicu (7) koja je učvršćena na nosač (4) koji je učvršćen na telo pumpe (2). Dvokraka poluga (6) može da se zakreće u vertikalnoj ravni. Na suprotnom kraju dvokrake poluge (6) učvršćena je osovinica (5) na koju je okačeno klatno (3) koje može da se njiše u vertikalnoj ravni koja prolazi kroz vertikalnu osu tela pumpe (2).

Centrifugalne i gravitacione sile koje se javljaju pri njihanju klatna (3) preko povezanih poluga (6), (8) i (9) uzrokuju osciliranje klipa (1), odnosno isticanje vode. Klatno (3) je potrebno samo povremeno zanjihavati, što znači da su obe ruke slobodne za prihvatanje vode.

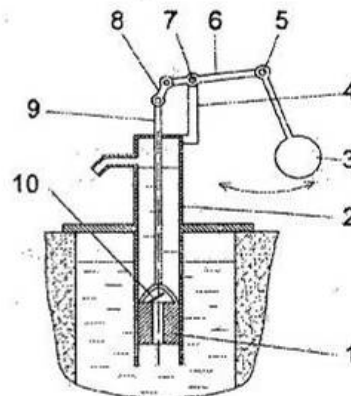

YU 49002 B

Slika 3. Patent br. YU 49002 B – Ručna pumpa za vodu sa klatnom
 pronalazač: Veljko Milković; broj prijave: P - 577/99;
 datum prijave: 10. novembar 1999; datum patenta: 30. april 2003.

49002 B

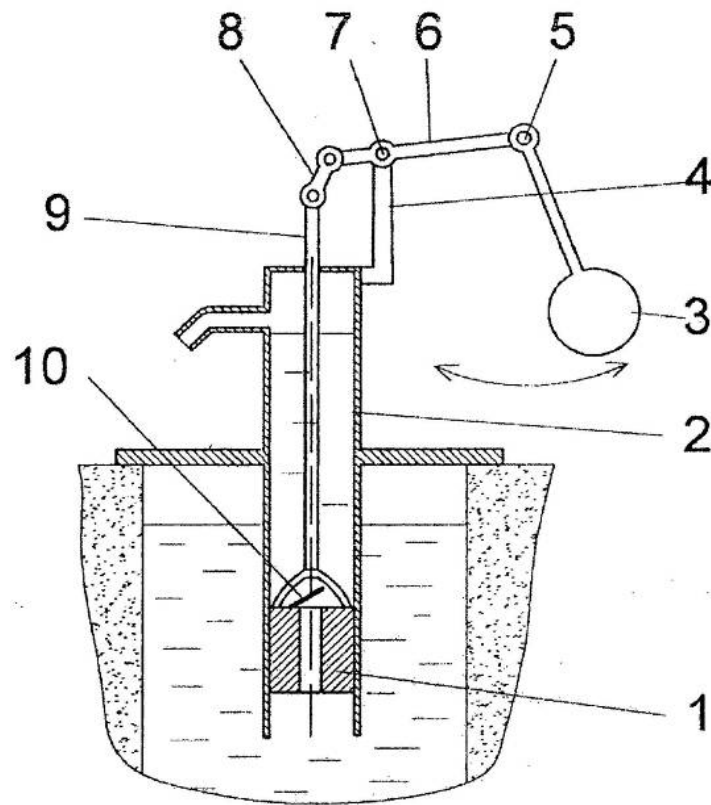

Slika 1.

Izdaje i štampa: Zavod za intelektualnu svojinu, Beograd, Zmaj Jovina 21

4

Slika 4. Patent br. YU 49002 B – Ručna pumpa za vodu sa klatnom
pronalazač: Veljko Milković; broj prijave: P - 577/99;
datum prijave: 10. novembar 1999; datum patenta: 30. april 2003.

Veliki odjek u svetu ostvaren je posebno u Indiji gde se dvostepeni oscilator izučava naučno i eksperimentalno na brojnim indijskim univerzitetima.



Slika 5. Replika ručne pumpe za vodu sa klatnom na koledžu u Indiji, Arun Sahoo, 2013. video link: <http://youtu.be/8n7mvpLpP5A>

Postavljanjem nove elastične strukture ostvarene su višestruko veće brzine oscilovanja, a da pri tom nije povećana cena budućeg proizvoda. Međutim, dalja istraživanja su svakako zahtevna.



Slika 6. Prvi model sa piezoelektričnim generatorima pogodan za istraživanja. video link: <https://youtu.be/jg55q5sJnbk>

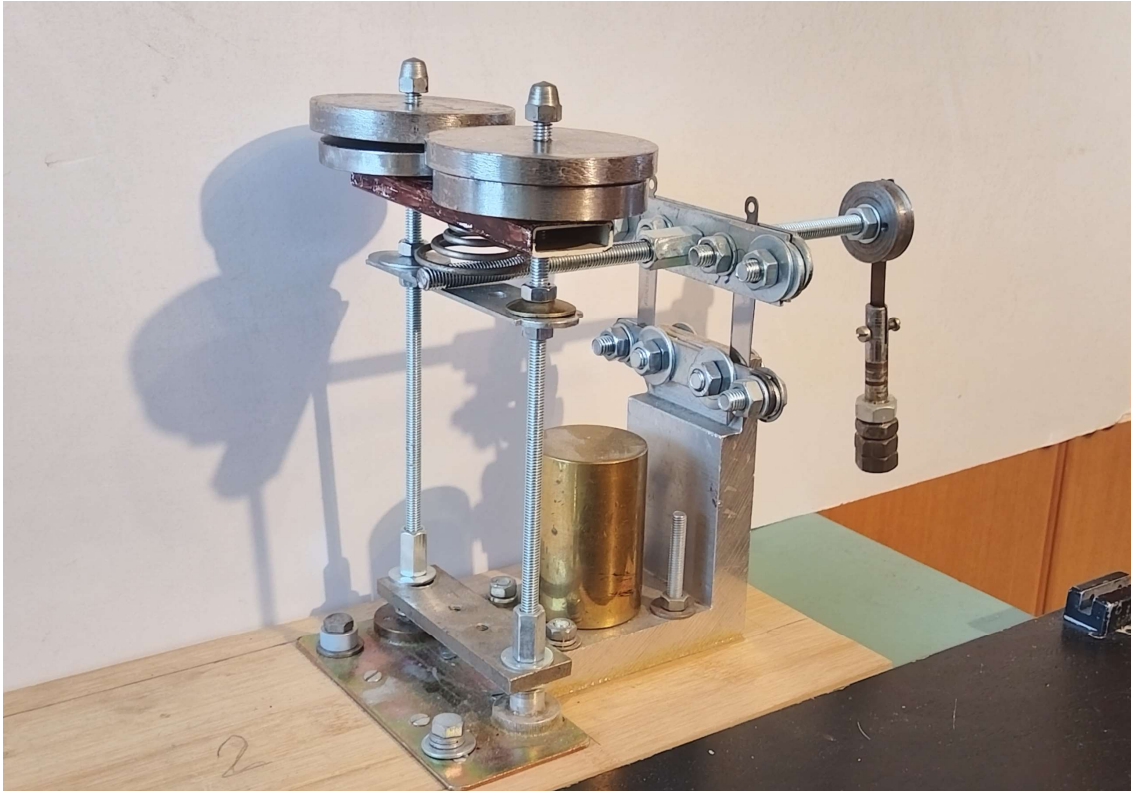

Slika 7. Prvi model sa piezoelektričnim generatorima pogodan za istraživanja.
video link: <https://youtu.be/jg55q5sJnbk>

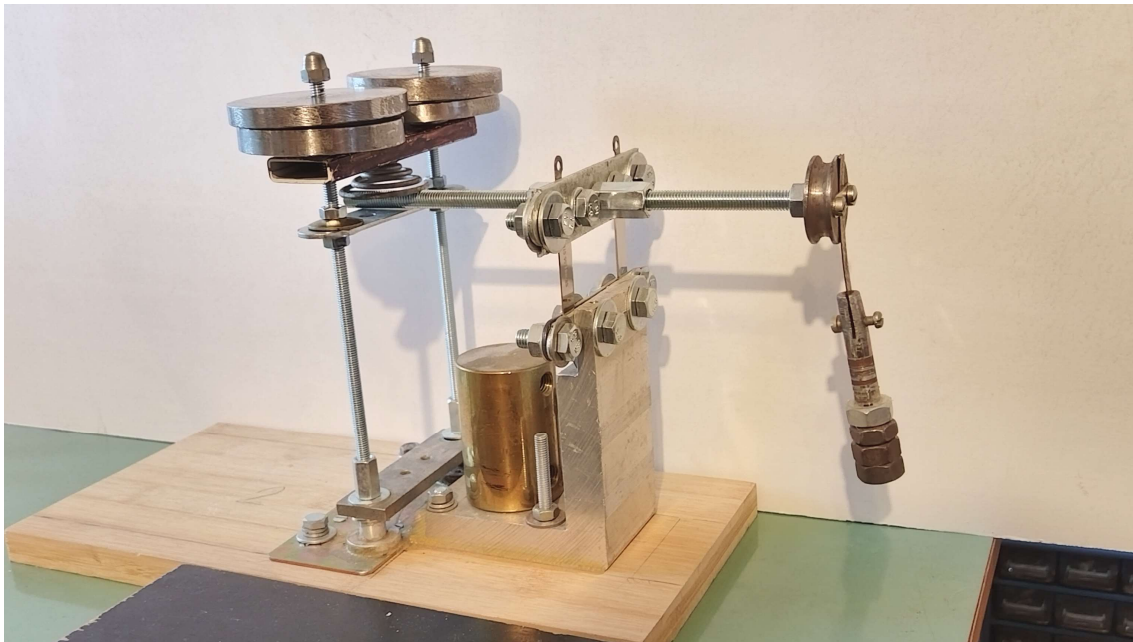

Slika 8. Prvi model sa piezoelektričnim generatorima pogodan za istraživanja.
video link: <https://youtu.be/jg55q5sJnbk>

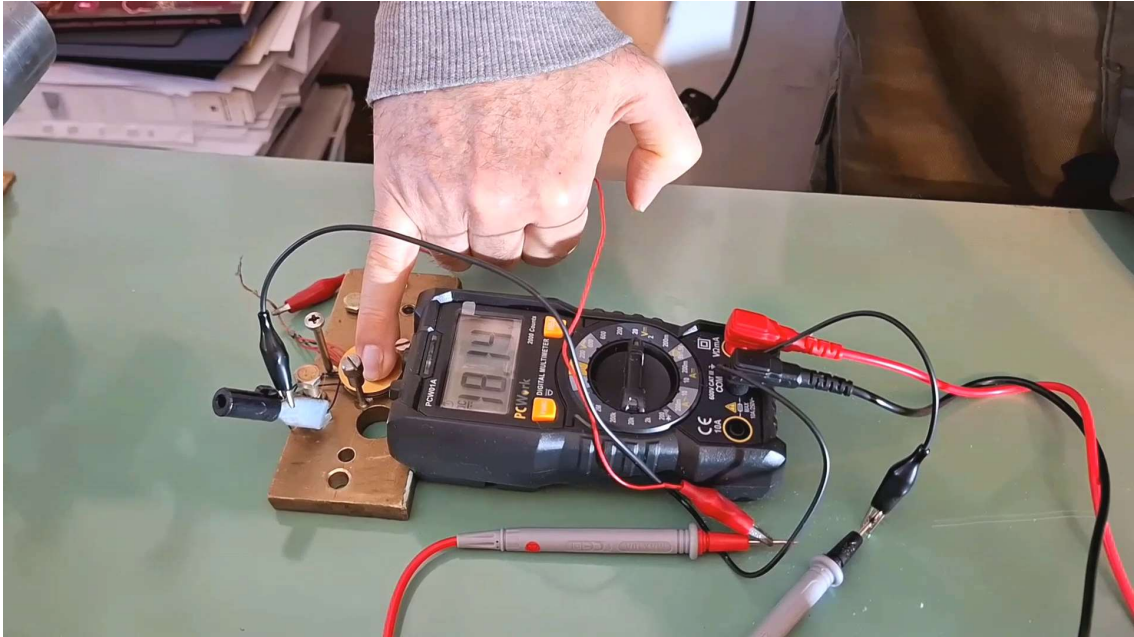

Slika 9. Prve probe sa piezoelektričnim stubom, 2025.
video link: <https://youtu.be/ipAly5J8Xlc>



Slika 10. Veljko Milkovićevo dvostepeno oscilujuće klatno
– zatvoren sistem u Indiji. video link: <https://youtu.be/g8YZE2M3eds>

Dvostepeni oscilator je početkom 2000-ih doživeo ekspanziju međunarodnih istraživanja u svetu, najviše zahvaljujući internet prezentacijama koje su omogućile laku i brzu međunarodnu razmenu naučnih podataka. Pored velikog broja stranih naučnih radova, najviše na temu primene ovog pronalaska u vodosnabdevanju i elektroenergetici, poslednjih godina ogroman broj inženjerskih kompanija u Kini, Indiji i drugim zemljama jugoistočne Azije, istražuje, razvija i proizvodi razne tehničke uređaje, najčešće mašine za tešku industriju, od kojih neke prodaju svoje proizvode pod imenom Veljka Milkovića, na elektronskim trgovačkim platformama kao što je kineska *Alibaba* (slika 11). <https://www.alibaba.com/trade/search?fsb=y&SearchText=veljko+milkovic>

The screenshot displays the Alibaba.com search results page for 'veljko milkovic'. At the top, there is a blue navigation bar with 'Mórch Expo' and 'Fast shipping: 24h dispatch during the holidays'. Below this is the Alibaba.com logo and a search bar containing 'veljko milkovic'. Navigation links include 'All categories', 'Featured selections', 'Order protections', and 'Source'. The main content area shows 'Showing 1,000+ products from global suppliers for "veljko milkovic"' and a 'FREE shipping on your first order' banner. A 'Filters' sidebar is visible on the left. The product listing for 'mtw european trapezium mill veljko milkovic' is shown, including a product image of a large industrial mill, its price range (\$80,000.00 - \$200,000.00), power (280K), and model number (MTW110). Payment options like VISA, MasterCard, and WesternUnion are listed at the bottom.

Slika 11.

A FAST TWO-STAGE OSCILLATOR WITH A NEW ELASTIC STRUCTURE

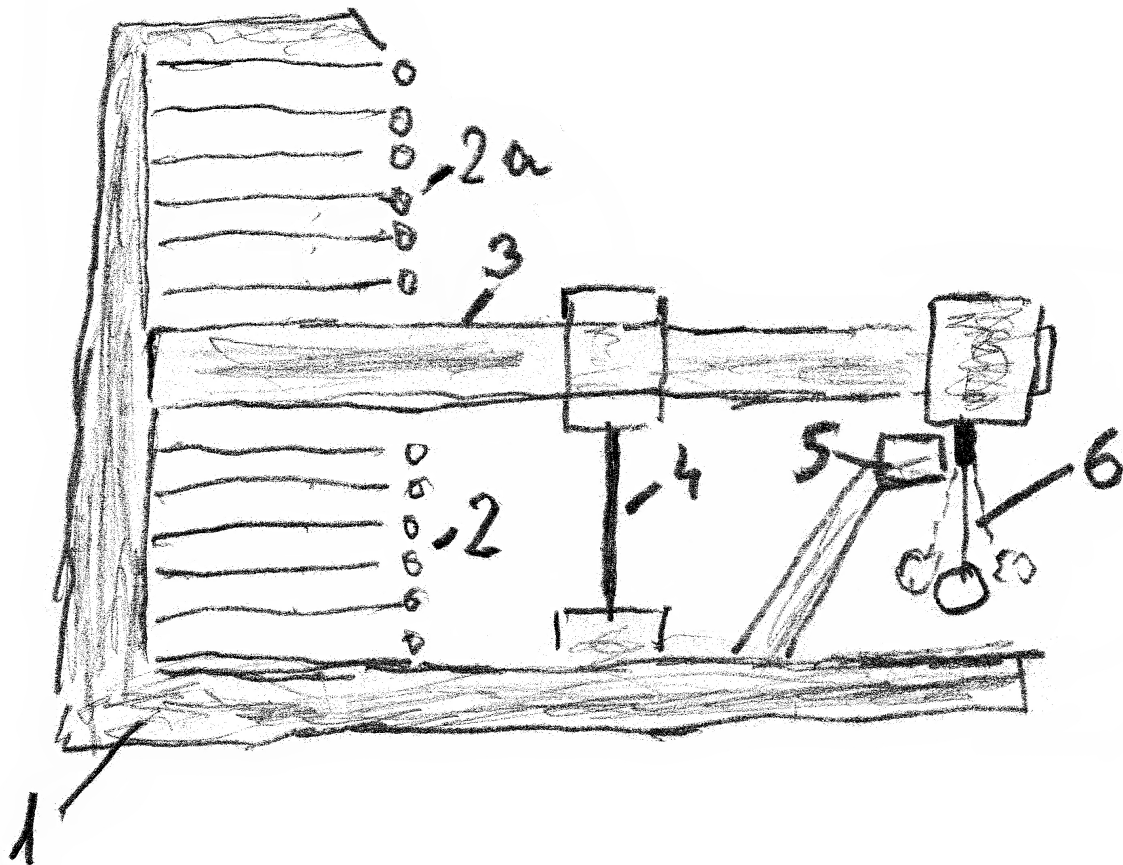

Figure 1.

- 1 – pedestal
- 2 – lower piezoelectric pile (piezo stack)
- 2a – upper piezoelectric pile (piezo stack)
- 3 – lever
- 4 – elastic lever support
- 5 – electromagnetic automatics (similar to an electric bell, where a timer (time trigger) can also be used to turn it on only occasionally)
- 6 – fast elastic pendulum with small amplitude (vertical, inclined or horizontal as needed)

In previous models of two-stage oscillators, larger amplitudes of the physical pendulum were represented, which were suitable especially for water pumps (patent P-577/99). After that, about 30 more technical solutions (designs) were officially published.

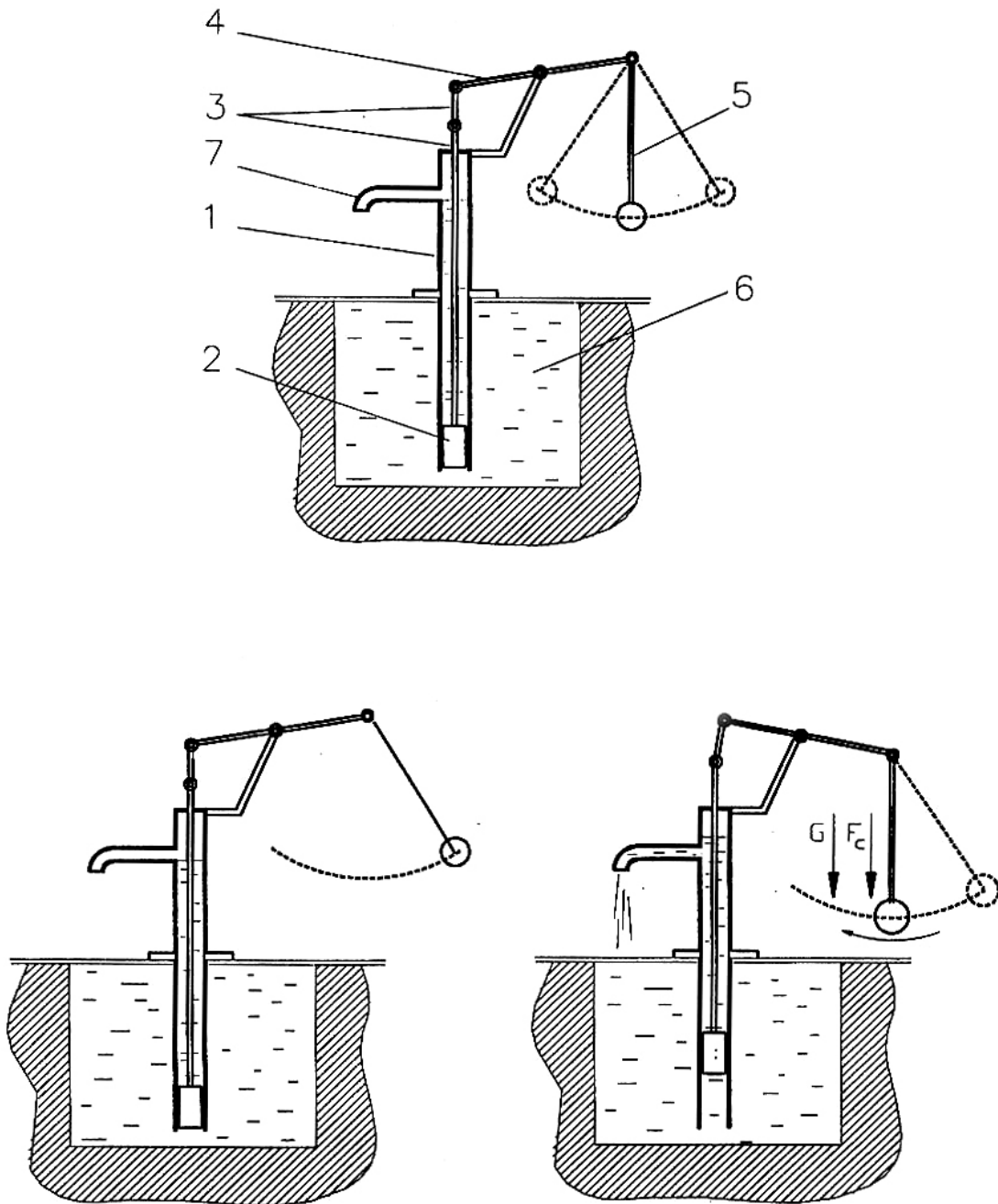

Figure 2. Patent application figures no. P - 577/99 – Hand Water Pump with a Pendulum (inventor: Veljko Milkovic; filed: November 10, 1999) published in Intellectual Property Gazette of Serbian Intellectual Property Office during the examination of meeting formal requirements.

(19) SRBIJA I CRNA GORA



ZAVOD ZA
INTELEKTUALNU SVOJINU
BEOGRAD

(12) Patentni spis (11) 49002 B

(51) Int. Cl.⁷

F 04 B 9/14

(21) Broj prijave: P-577/99
 (22) Datum podnošenja prijave: 10.11.1999.
 (43) Datum objavljivanja prijave: 28.05.2001.
 (45) Datum objavljivanja patenta: 30.04.2003.
 (30) Međunarodno pravo prvenstva:
 (61) Dopunski patent uz osnovni patent broj:
 (62) Izdvojen patent iz prvobitne prijave broj:

(73) Nosilac patenta:
MILKOVIĆ VELJKO,
 Bul. Cara Lazara 56,
 21000 Novi Sad

(72) Pronalazač:
MILKOVIĆ VELJKO

(74) Zastupnik:

(54) Naziv: **RUČNA PUMPA ZA VODU
 SA KLATNOM**

(51) Int. Cl.⁷

F 04 B 9/14

(57) Apstrakt:

Pronalazak, ručna pumpa za vodu sa klatnom, sastavljen je iz tela pumpe (2) u obliku cilindra u kojem je smešten klip (1) sa klapnom (10) koja je jednosmerno propusna za vodu, tj. voda može da prolazi kroz klip (1) samo prema gore i to kada se on kreće prema dole. Za klip (1) je čvrsto spojena poluga (9) koja je sa gornje strane zglobno spojena sa polugom (8). Poluga (8) je sa druge strane zglobno spojena sa jednim krajem dvokrake poluge (6), koja je okačena na osovinicu (7) koja je učvršćena na nosač (4) koji je učvršćen na telo pumpe (2). Dvokraka poluga (6) može da se zakreće u vertikalnoj ravni. Na suprotnom kraju dvokrake poluge (6) učvršćena je osovinica (5) na koju je okačeno klatno (3) koje može da se njiše u vertikalnoj ravni koja prolazi kroz vertikalnu osu tela pumpe (2).

Centrifugalne i gravitacione sile koje se javljaju pri njihanju klatna (3) preko povezanih poluga (6), (8) i (9) uzrokuju osciliranje klipa (1), odnosno isticanje vode. Klatno (3) je potrebno samo povremeno zanjihavati, što znači da su obe ruke slobodne za prihvatanje vode.

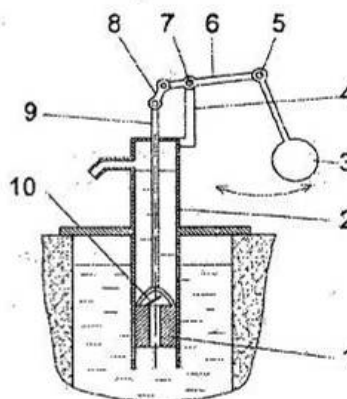

YU 49002 B

Figure 3. Patent no. YU 49002 B – Hand Water Pump with a Pendulum
 inventor: Veljko Milkovic; application no: P - 577/99;
 filed: November 10, 1999; date of patent: April 30, 2003.

49002 B

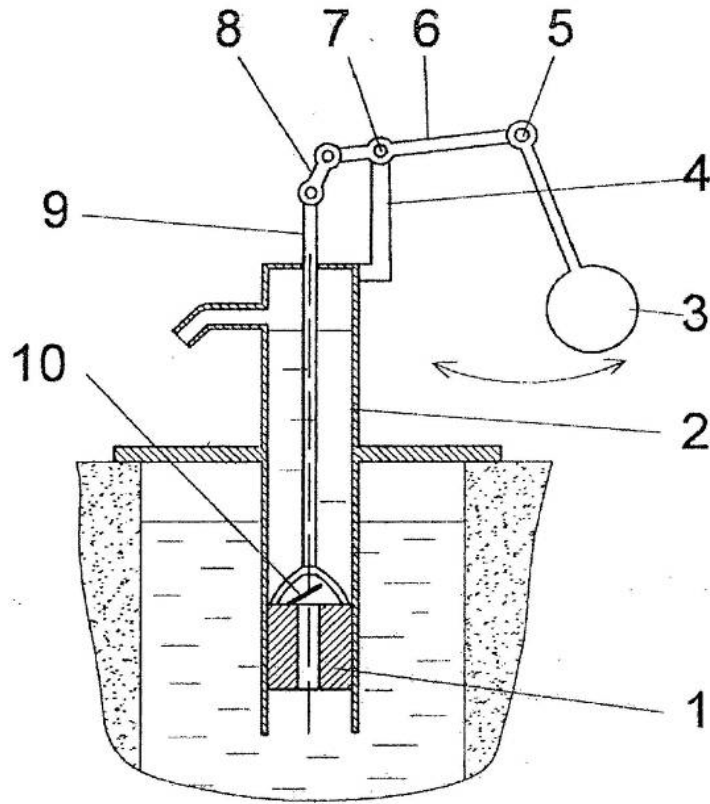

Slika 1.

Izdaje i štampa: Zavod za intelektualnu svojinu, Beograd, Zmaj Jovina 21

4

Figure 4. Patent no. YU 49002 B – Hand Water Pump with a Pendulum
inventor: Veljko Milkovic; application no: P - 577/99;
filed: November 10, 1999; date of patent: April 30, 2003.

A great feedback in the world was achieved especially in India, where the two-stage oscillator is studied scientifically and experimentally at numerous Indian universities.

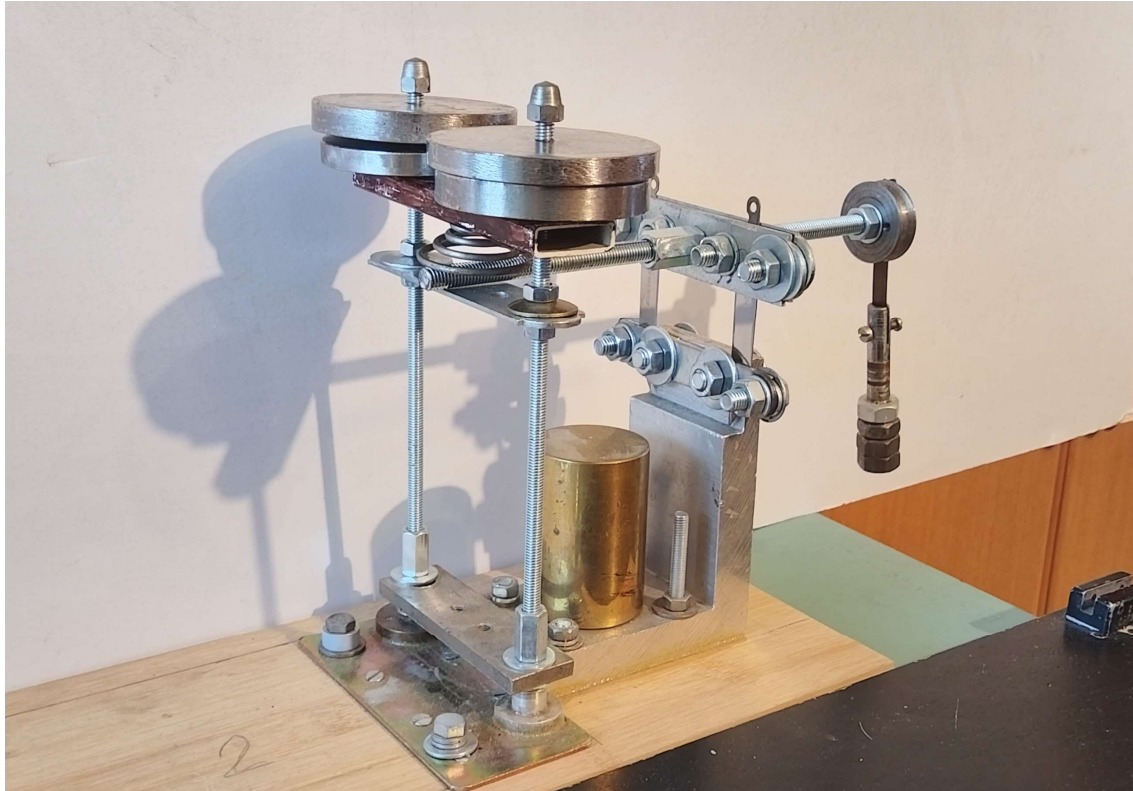

Figure 5. A replica of a hand water pump with a pendulum in a college in India, Arun Sahoo, 2013. video link: <http://youtu.be/8n7mvpLpP5A>

By installing a new elastic structure, several times higher oscillation speeds were achieved, without increasing the price of the future product. However, further research is certainly demanding.



Figure 6. The first model with piezoelectric generators suitable for research. video link: <https://youtu.be/jg55q5sJnbk>



*Figure 7. The first model with piezoelectric generators suitable for research.
video link: <https://youtu.be/jg55q5sJnbk>*

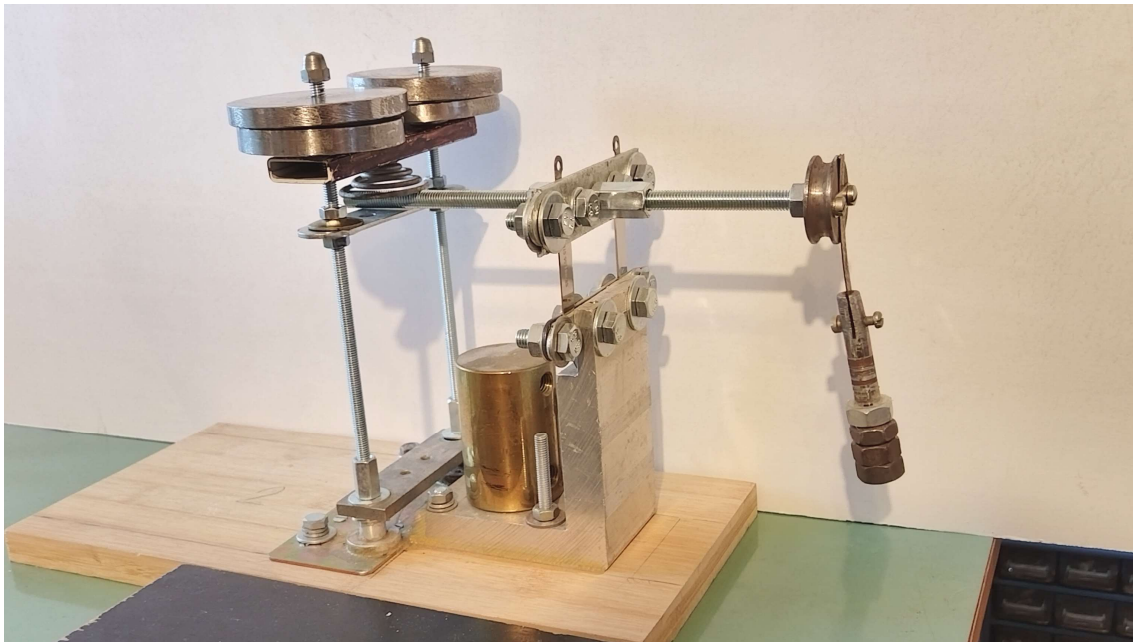

*Figure 8. The first model with piezoelectric generators suitable for research.
video link: <https://youtu.be/jg55q5sJnbk>*

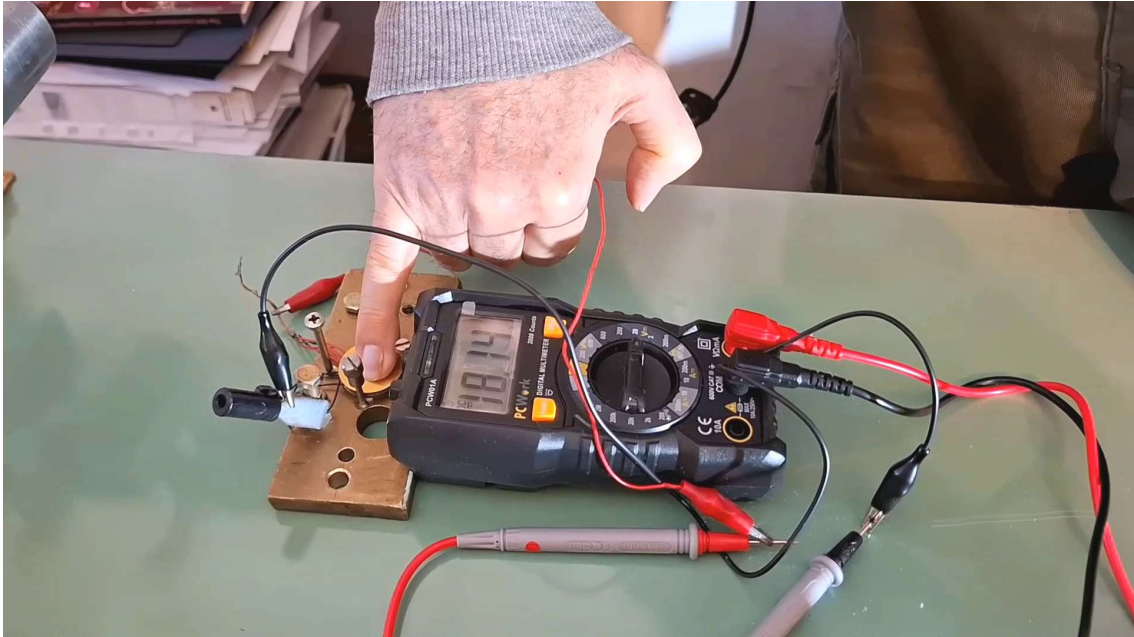

Figure 9. First tests with a piezoelectric pile (piezo stack), 2025.
video link: <https://youtu.be/ipAly5J8Xlc>



Figure 10. Veljko Milkovic's two-stage oscillating pendulum – closed system
in India. video link: <https://youtu.be/g8YZE2M3eds>

In the early 2000s, the two-stage oscillator experienced an expansion of international research in the world, mostly thanks to Internet presentations that enabled easy and fast international exchange of scientific data. In addition to a large number of international scientific papers, mostly on the subject of the application of this invention in water supply and power generation, in recent years a huge number of engineering companies in China, India and other Southeast Asian countries research, develop and produce various technical devices, most often machines for heavy industry, some of which sell their products under the name of Veljko Milkovic, on e-commerce platforms such as China's *Alibaba.com* (figure 11).

<https://www.alibaba.com/trade/search?fsb=y&SearchText=veljko+milkovic>

The image shows a screenshot of an Alibaba.com product listing. At the top, there is a blue banner with 'March Expo' and 'Fast shipping: 24h dispatch during the holidays'. Below this is the Alibaba.com search bar with 'veljko milkovic' entered. The search results show 'Showing 1,000+ products from global suppliers for "veljko milkovic"'. A filter for 'Alibaba Guaranteed' is visible. The product listing is for 'mtw european trapezium mill veljko milkovic'. The price is listed as '\$80,000.00 - \$200,000.00 / Sets | 1 Set/Sets (Min. Order)'. The power is '280K' and the model number is 'MTW110'. Payment options include VISA, Online Bank Payment, T/T, Pay Later, and WesternUnion. A large image of the mill is shown on the left.

Figure 11.

ISTRAŽIVAČKO-RAZVOJNI CENTAR VELJKO MILKOVIĆ
VELJKO MILKOVIC RESEARCH & DEVELOPMENT CENTER

Brzi dvostepeni oscilator sa novom elastičnom strukturom
A Fast Two-Stage Oscillator with a New Elastic Structure

Prvo izdanje na srpskom i engleskom jeziku (latinično pismo, štampa u boji), maj 2026.
First edition in Serbian and English language (color printing), May 2026

Copyright © 2026 Veljko Milković

Izdavač / Published in Serbia by
Istraživačko-razvojni centar Veljko Milković – VEMIRC
Bulevar cara Lazara 56, 21000 Novi Sad, Srbija
www.veljkomilkovic.com www.vemirc.com

Za izdavača / For the publisher
Veljko Milković, akademik SAIN & EAN / academician of SAIN & EAN

Urednik / Editor
Alen Panjković

Prevod na engleski / English translation
Alen Panjković

Dizajn i priprema / Design & Prepress
Alen Panjković

Sva prava zadržana. Nijedan deo ove publikacije ne može biti reprodukovan niti smešten u sistem za skladištenje podataka ili prenesen u bilo kom obliku: elektronski, mehanički, fotokopiranjem, snimanjem ili na drugi način, bez prethodne pismene dozvole nosioca autorskih prava.

All rights reserved. No part of this publication may be reproduced, stored in a retrieval system, or transmitted in any form or by any means electronic, mechanical, photocopying, recording, or otherwise, without the prior written permission of the copyright holder.

The Matica Srpska Library Cataloging-in-Publication Data

CIP – Katalogizacija u publikaciji
Biblioteke Matice Srpske, Novi Sad

62-119
621.37

MILKOVIĆ, Veljko, 1949-

Brzi dvostepeni oscilator sa novom elastičnom strukturom = A Fast Two-Stage Oscillator with a New Elastic Structure / Veljko Milković ; [prevod na engleski Alen Panjković]. - 1. izd. - Novi Sad : Istraživačko-razvojni centar Veljko Milković - VEMIRC, 2026 (Novi Sad : Studio R2). - 18 str. : ilustr. ; 30 cm

Uparedo srp. tekst i engl. prevod. - Tiraž 50.

ISBN 978-86-88883-13-9

a) Oscilatori

COBISS.SR-ID 194721545

Kontakt / Contact

Istraživačko-razvojni centar Veljko Milković – VEMIRC
Bulevar cara Lazara 56, 21000 Novi Sad, Srbija
e-mail: office@veljkomilkovic.com
vemircbooks.com

Štampano u Srbiji / Printed in Serbia



ISBN 978-86-88883-13-9



9 788688 883139 >